



SBP-300HM7

Hanging Adaptor



Key Features

- Materials : Aluminum
- Dimensions (WxHxD) : Ø120.0 x51.5mm(Ø4.72" x 2.02")
- Weight : 145g (0.32 lb)
- Color : Ivory
- Mount screw size : PF 1 1/2"

SBP-300HM7

Hanging Adaptor



Specifications

Mechanical	
Color	Ivory
Material	Aluminum
Product dimensions / weight	ø120x51.5mm / 145g
Supported products	XND-6020R, XND-8020R ※ For further compatible models, please visit our website or use Toolbox

SBP-300HM7

Hanging Adaptor



CAD

Unit: mm [inch]

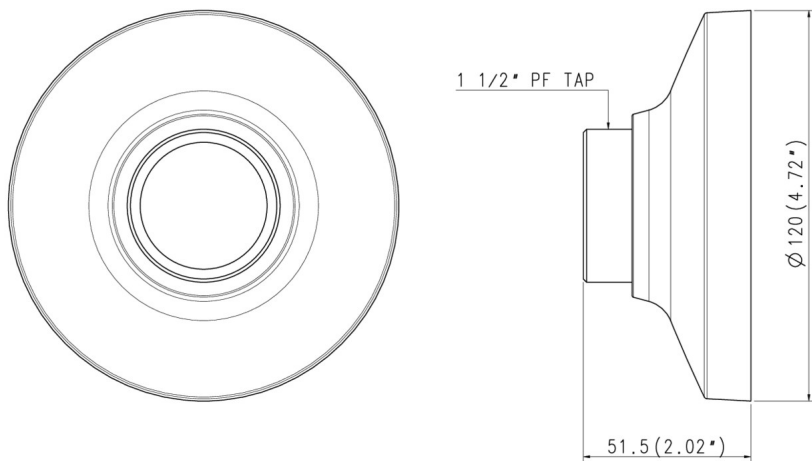

SBP-300HM7