



SBP-301HM5

Hanging Adaptor



Key Features

- Weight : 197g
- Material : Aluminum
- Operation temp. : -50°C~60°C
- Operation hum. : 0~100%
- Mount screw size : PF 1 1/2"

Compatible Devices



SBP-300CM



SBP-300WM1



SBP-300LM



SBP-300WM

SBP-301HM5

Hanging Adaptor



Specifications

Mechanical	
Color	Ivory
Material	Aluminum
Product dimensions / weight	ø144x51mm / 197g
Supported products	XNP-6040H ※ For further compatible models, please visit our website or use Toolbox

SBP-301HM5

Hanging Adaptor



CAD

Unit: mm [inch]

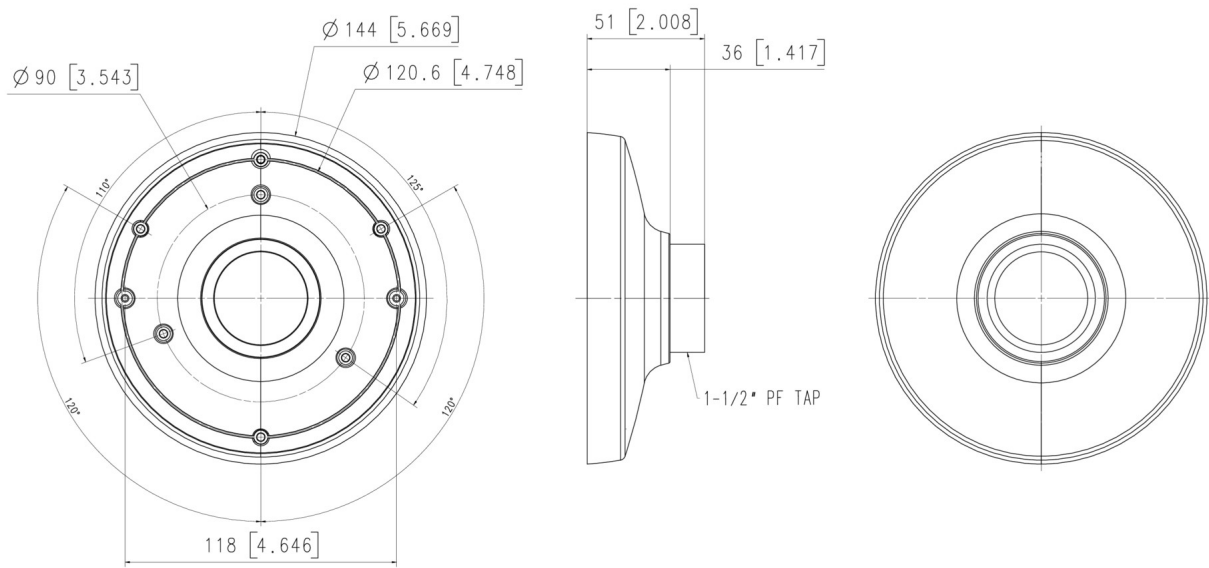

UNIT : mm [inch]