

Roger Access Control System

Installation guide for HRT82MF type card reader

Firmware version: 1.0.2.6 or newer

Hardware version: 1.2

Document version: Rev. G

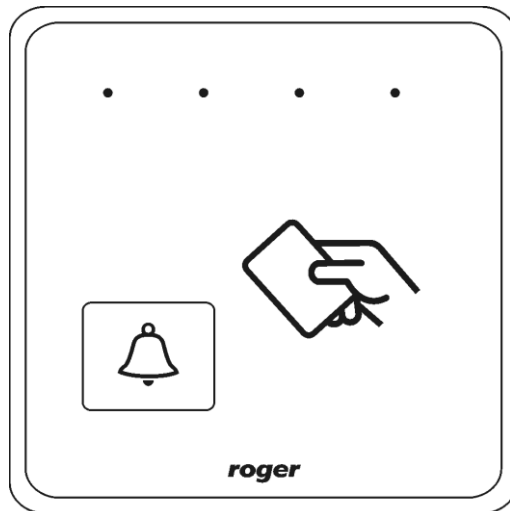

rcdr199

1. INTRODUCTION

This manual contains minimum information that is necessary to properly install device. Following documents supplement this manual:

- Functional description of HRC series controllers
- Installation guide for HRC series controllers
- Functional description of PRxx2 series controllers
- Functional description of PRxx1 series controllers
- PR821-CH User Manual

In order to acquire the first one it is necessary to obtain Roger consent and to sign non-disclosure agreement (NDA). The remaining ones are available at www.roger.pl.

2. DESCRIPTION AND SPECIFICATION

HRT82MF type proximity card reader is peripheral device used both in RACS 4 system and hotel system based on HRC series controllers. The device communicates with controller using RACS CLK/DTA bus and enables MIFARE® card number reading for the purpose of user identification and access granting. The reader enables serial number (CSN) reading for such cards as MIFARE Ultralight/Classic/Plus/Desfire. Additionally it allows to read programmed card number (PCN) for MIFARE Classic cards.

The front panel of HRT82MF and HRT82MF-F includes touch key and four LED indicators for signalling such hotel indications as 'Hotel staff presence', 'Do not disturb', 'Make up room' and 'Assistance'. Indicators can be used for hotel functions only when the reader is connected to PR821-CH controller of RACS 4 system or to HRC controller. Other PRxx1 and PRxx2 series controllers of RACS 4 system treat the reader as standard PRT reader. In such scenario indicators are used to signal built-in function e.g. access granting. Function key is available and configurable in all possible scenarios of operation.

Table 1 Versions of HRT82MF type reader					
Model	LED indicators	Bell button	RACS 4 system	Hotel system with HRC controllers	Wall mounting
HRT82MF	Yes	Yes	Mainly for PR821-CH hotel controller	Yes	Surface
HRT82MF-F	Yes	Yes	as above	Yes	Flush
HRT82MF-GP-F	No	No	Yes	Yes	Flush

Table 2. Specification	
Supply voltage	Nominal 12VDC, min./max. range 10-15VDC
Proximity cards	13.56MHz in acc. with ISO14443A and MIFARE
Reading distance	Up to 15 cm for ISO cards (depends on card type and quality)
Average current consumption	60mA
Tamper resistance	Isolated contact, NC type (normally closed when enclosure is assembled and attached), 24V/50mA
Distance	Between controller and HRT device (RACS CLK/DTA): max. 150m
Environmental class (acc. to EN 50131-1)	Class II, indoor general conditions, temperature: -10°C- +50°C, relative humidity: 10 to 95% (no condensation)
IP code	IP41

Dimensions HxWxD	HRT 82MF: 85 x 85 x 22 mm HRT82MF-F: 105 x 105 x 31 mm HRT82MF-GP-F: 105 x 105 x 31 mm
Weight	~ 100g
Certificates	CE

3. INSTALLATION

3.1 Terminals and connection diagram

HRT82MF-F and HRT82MF-GP-F readers are equipped with removable screw terminals while HRT82MF is equipped with standard screw terminals.

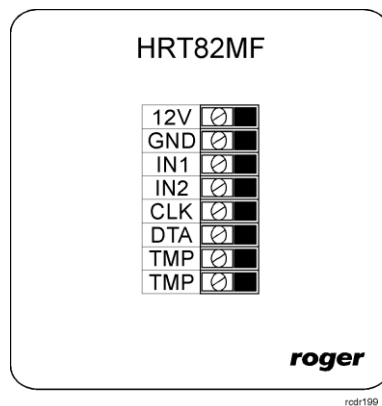

Fig. 1 HRT82MF type card reader

Term.	Description	Term.	Description
12V	12VDC power supply	CLK	RACS CLK/DTA bus
GND	Ground	DTA	RACS CLK/DTA bus
IN1	not used	TMP	Tamper
IN2	not used	TMP	Tamper

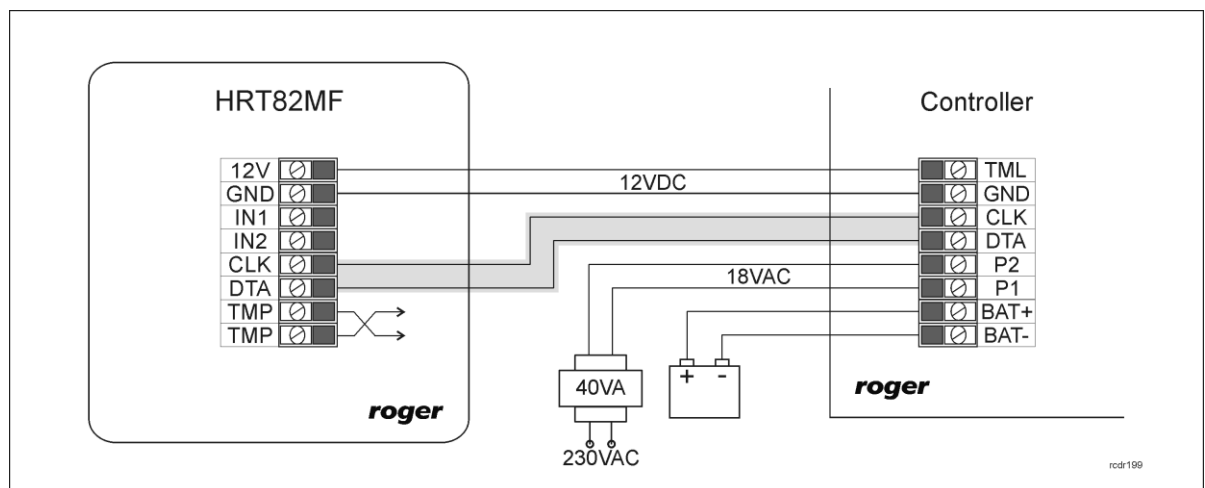

Fig. 2 Connection to controller with 12VDC power supply output (PR402DR, PR411DR, HRC402DR)

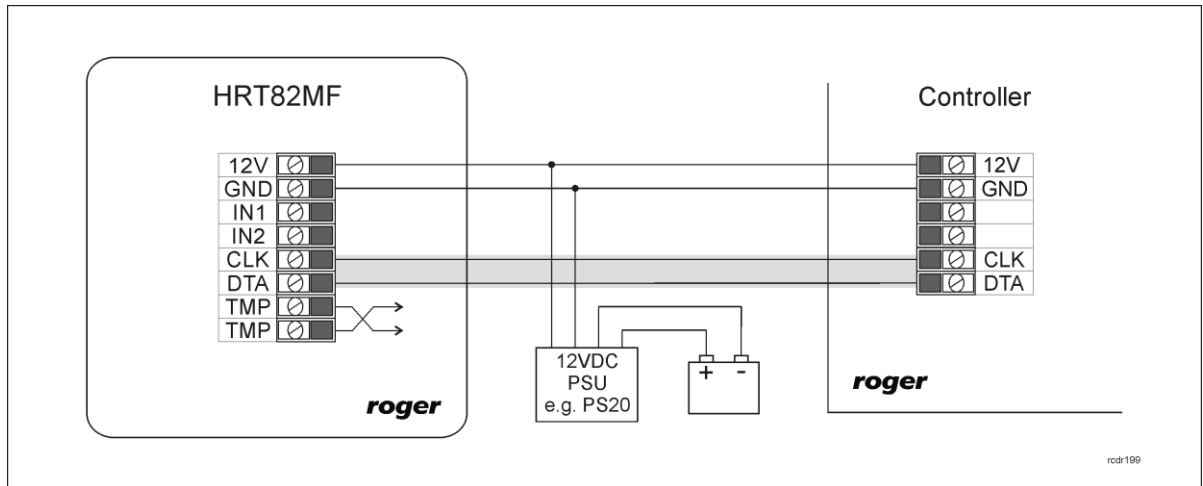

Fig. 3 Connection to controller without 12VDC power supply output

3.2 Power supply

HRT82MF requires 12VDC nominal power supply. The power must be connected to 12V and GND terminals. Additionally, the GND terminal is used as reference potential for the RACS CLK/DTA bus. HRT82MF power supply can be provided by connection to buffer power supply unit (e.g. PS20) or connection to TML output of PR402DR, PR411DR or HRC402DR controller (see fig. 2). Backup battery connected to power supply unit or directly to the controller can be used in order to ensure operation in case of 230VAC power failure.

Note: All devices connected to the same RACS CLK/DTA bus must be connected to common reference potential (GND).

3.3 RACS CLK/DTA communication bus

RACS CLK/DTA is the addressable bidirectional communication standard developed and applied in Roger controllers in order to enable their communication with peripheral devices. Addresses of all devices connected to CLK and DTA lines must be properly configured in range of 00..15. Standard unshielded signal cables (e.g. U/UTP cat. 5) with maximal length of 150m can be used for RACS CLK/DTA communication.

3.4 Front panel

LED indicators

In the top part of HRT82MF and HRT82MF-F readers there are located four LED indicators. Their functions are explained in table 4 and they depend on type of connected controller.

Table 4. LED indicators				
Name	Colour	Function		
		PR821-CH controller	Remaining RACS 4 controllers	HRC controller
HOTEL STAFF	Green	Presence of hotel staff card in card holder	-	Programmable
MUR	Orange	Activated 'make up room' flag	Access granting	Programmable
ASSIS-TANCE	Blue	Activated 'assistance' flag	-	Programmable

DND	Red	Activated 'do not disturb' flag'	Armed mode	Programmable
-----	-----	----------------------------------	------------	--------------

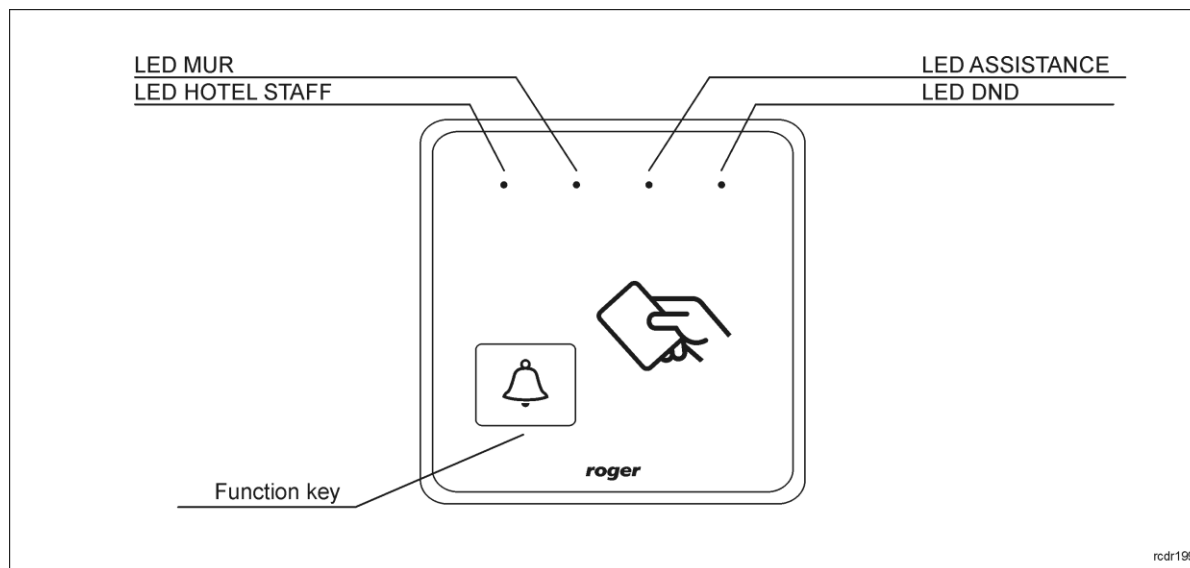

Fig. 4 Indicators and function key

Note: HRT82MF-GP reader is not equipped with LED indicators shown in fig. 4 but its backlight color can be controlled. By default it is white but as long as MUR indicator is activated by controller it changes its color into green. Therefore in case of connection to RACS 4 controller other than PR821-CH, access granting is represented by green backlight on the front panel.

Function key (bell)

HRT82MF and HRT82MF-F readers are equipped with touch button dedicated to entry bell. However the function is programmable and the button can be used for various purposes.

3.5 Wall mounting and installation guidelines

HRT82MF consists of front panel and base which are factory assembled and require manual disassembly prior to installation according to fig. 5.

Installation guidelines

- Install device on wall far from sources of heat and moisture
- It is recommended to install HRT82MF model on Ø60mm flush mounting box
- Front panel and base must be properly oriented in order to ensure functioning of tamper resistance.
- All electric connections must be made with power supply switched off
- Run connection wires through hole in device base and then connect wires to screw terminals
- If device and controller are supplied from different power supply units then it is necessary connect GND terminals of both devices
- Front panel can be regularly cleaned with wet cloth and mild detergent. Do not clean by means of abrasive materials and strong cleaners like alcohols, solvents, etc.
- Damages resulting from improper maintenance or use are not covered by warranty

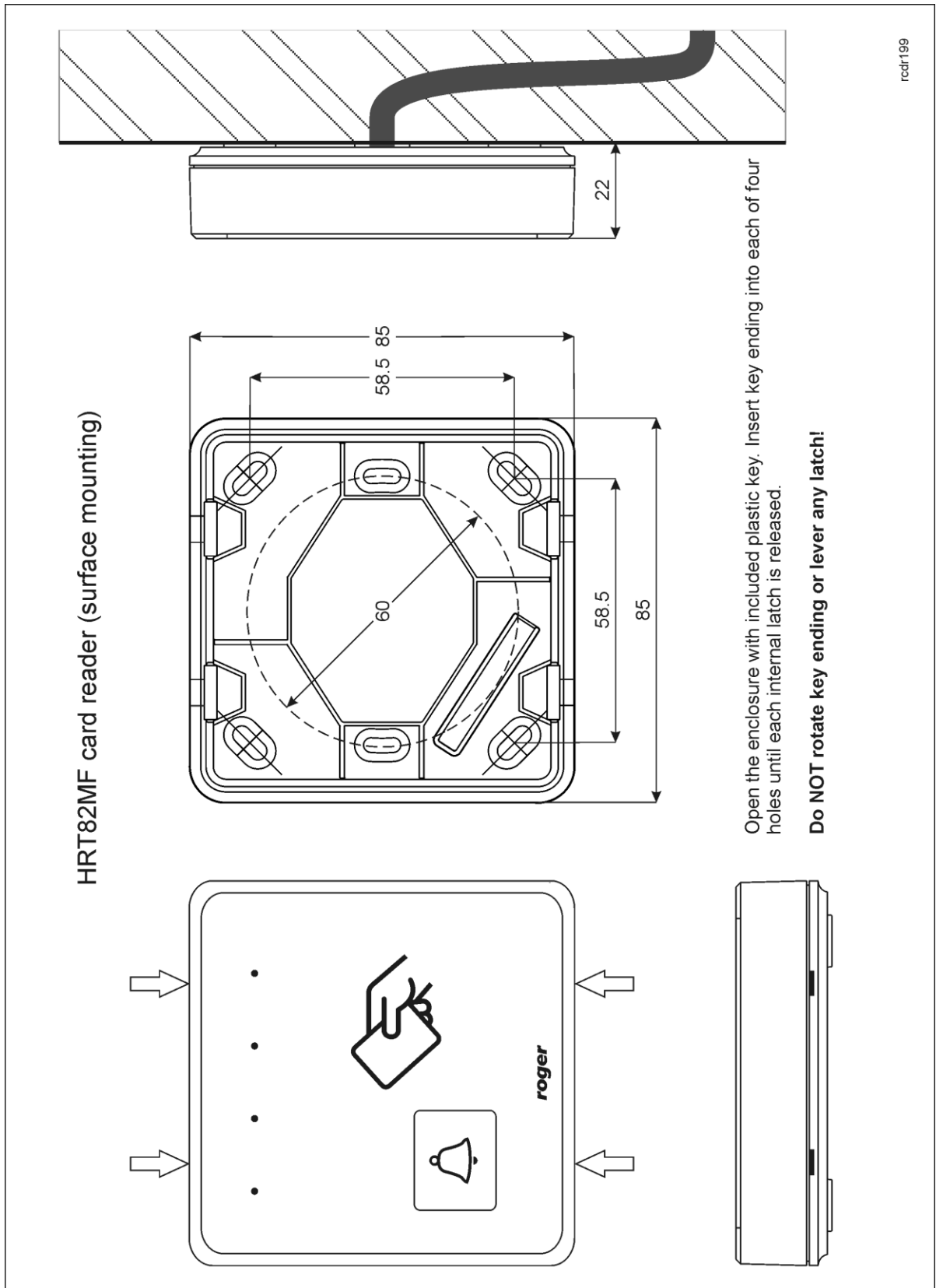

Fig.5 HRT82MF latches and wall mounting

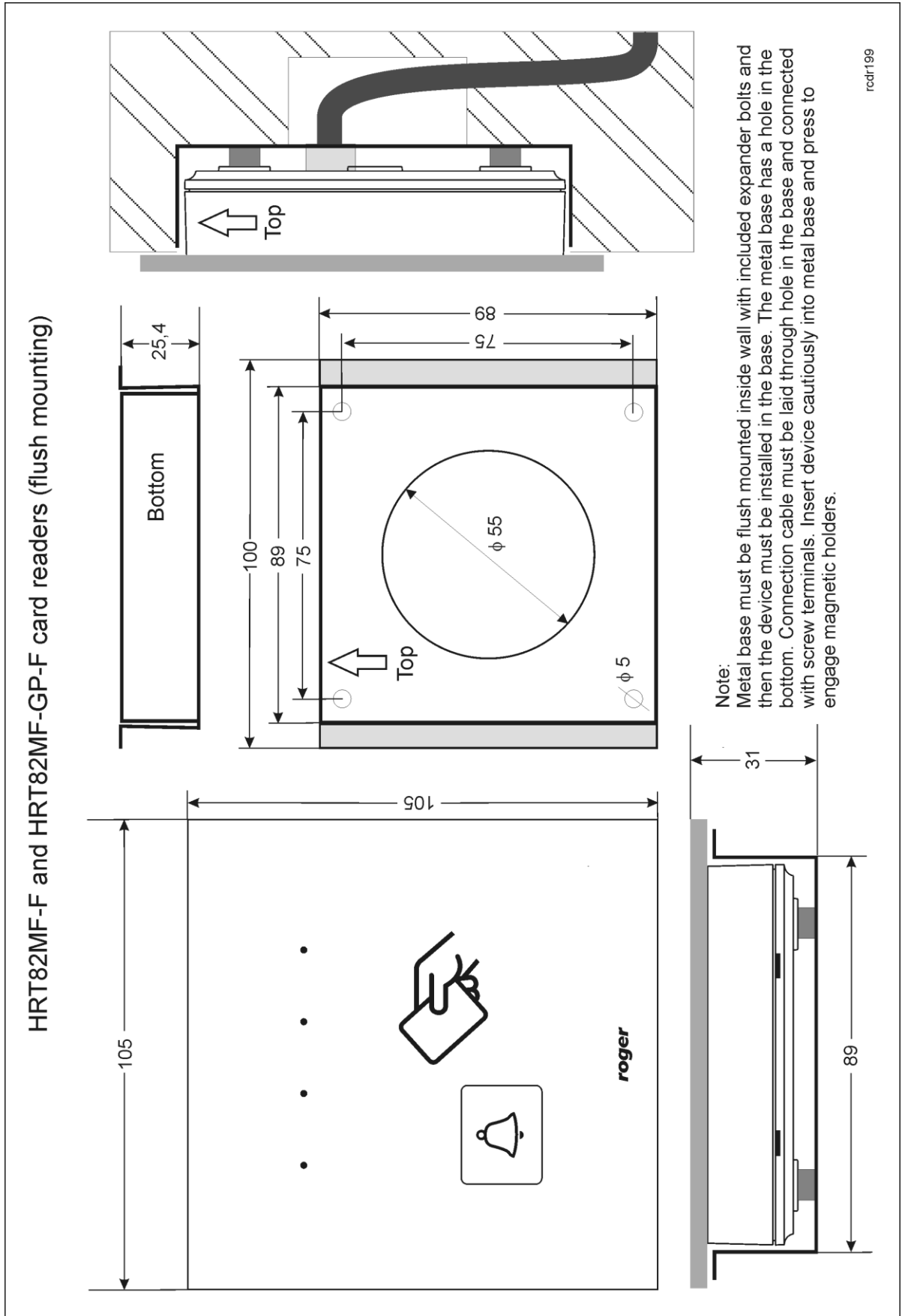

Fig.6 HRT82MF-F and HRT82MF-GP-F flush mounting

4. CONFIGURATION

4.1 Device programming

The address of factory new HRT82MF type reader is ID=0 and such device is ready to communicate with RACS 4 controllers with no additional configuration. Special versions of the reader can be configured with ID=1 address for operation with HRC controllers.

If necessary, HRT82MF settings including the address can be modified with RogerVDM software which is available at www.roger.pl after connection to RUD-1 communication interface.

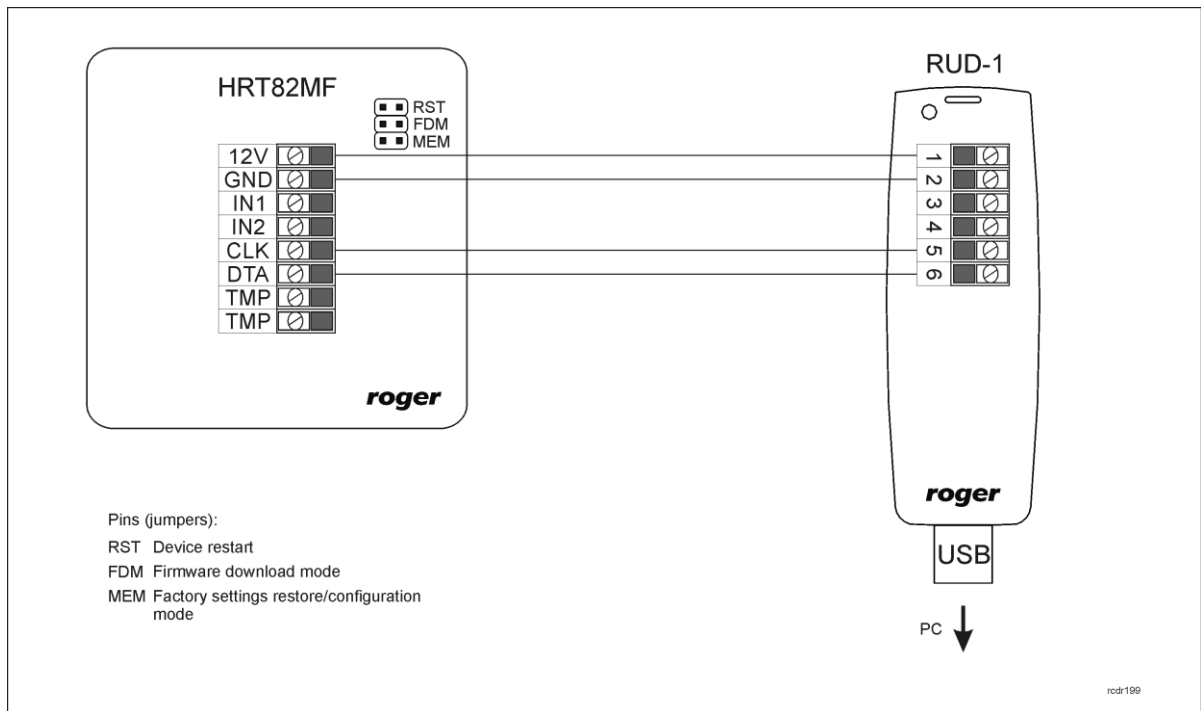

Fig. 7 HRT82MF and RUD-1 connection

Connection and configuration procedure

1. Connect device to RUD-1 communication interface according to fig. 7
2. Place jumper on MEM pins
3. Restart the device (place and remove jumper on RST pins or switch power supply off and on)
4. Install and start RogerVDM software
5. In the opened window select device, firmware version, communication channel and serial port with connected RUD-1
6. Select *Connect* button, the software shall establish connection with the device and automatically switch to configuration window
7. Enter required settings
8. Select *Send to Device* button – the software shall upload new settings
9. Remove jumper from MEM pins
10. Restart the device (place and remove jumper on RST pins or switch power supply off and on)

Note:

During connection procedure placing jumper on MEM pins and restarting the device restores its factory default settings.

Table 5. Configuration parameters		
Parameter	Values	Description
General		
Device Name	16 ASCII characters	Device description which can be filled with any comment by installer
Transmission Format		
RACS CLK/DTA Address	0..15	Device address on RACS CLK/DTA bus. Default address ID=1 is required for communication with HRC controller, while the address ID=0 is required for communication with PR821-CH controller.
Communication timeout [0.5s]	0..255	The device signals communication failure when selected timeout [0.5s] elapses. When 0 is selected then failure is not signalled at all.
Optical Signalization		
Keypad Backlight Level	0..100%	Keypad backlight level
Backlight Animation	On, Off	When activated, panel will temporary switch on keypad full backlight when card is read or key is pressed and dim the backlight afterwards.
Backlight Dim	On, Off	When activated, panel will temporary switch off keypad backlight when card is read or key is pressed.
Acoustic Signalization		
Buzzer loudness level	0..100%	Buzzer loudness level. Buzzer is switched off when 0 level is selected
Card Read Confirmation Signal on Buzzer	Yes, No	When activated, card reading is signalled with buzzer.
Key Press Confirmation Signal On Buzzer	Yes, No	When activated, button pressing is signalled with buzzer.
CSN Number Settings		
CSN Number of Bytes	0..8	The parameter specifies how many bytes of read only Chip Serial Number (CSN) is used in UID card number.
Mifare Classic Settings		
Card number	CSN, MSN, SSN	When CNS is selected then UID includes only this number. When MSN or SSN is selected then it is possible to use administrator defined UID. It is also possible to define UID consisting partially of CSN and MSN or SSN.
Format	BIN, HEX ASCII	Card number format. When BIN is selected then bytes from card correspond to UID number. When HEX ASCII is selected then bytes from card correspond to UID in ASCII hexadecimal format.
LSB	0..15	The location of MSN or SSN first byte.
MSB	0..15	The location of MSN or SSN last byte.
Sector ID	0..39	Sector number with SSN. For MSN this setting is disabled.

AID	0000..FFFF	AID number in MAD sector which defines sector with MSN. For SSN this setting is disabled.
Block ID	0..14	Block number in the sector with MSN or SSN.
Key Type	A, B , Roger	Type of key used for reading MSN or SSN.
Key	000000000000.. FFFFFFFFFFFFFF	Six bytes key used for reading MSN or SSN.
Advanced Settings		
Block card or PIN reading when buffer is full	yes, no	When activated, Card/PIN reading is stopped until buffer is empty.
Buffer clearing timeout [0.5s]	1..255	The device periodically resets its Card/PIN buffer when selected timeout [0,5s] elapses. When 0 is selected then buffer reset is off.
Card/PIN Frames Encryption	on, off	When activated, frames with data from Card/PIN buffer are encrypted (EEA).

4.2 Firmware update

HRT82MF firmware can be updated with RogerVDM (available at www.roger.pl) after connection to RUD-1 communication interface.

Firmware update procedure

1. Connect device to RUD-1 communication interface according to fig. 7
2. Install and start RogerVDM software
3. Close *Select Device* window
4. In top menu select *Tools->Update firmware*
5. In the opened window select device, port with connected RUD-1 and specify path to firmware file (*.hex)
6. According to displayed message place jumper on FDM pins and restart the device (place and remove jumper on RST pins or switch power supply off and on)
7. Select *Update* button
8. After firmware upload remove jumper from FDM pins and reset device (place and remove jumper on RST pins or switch power supply off and on)

4.3 Memory reset

In order to restore HRT82MF factory default settings place jumper on MEM pins and then restart the device either by placing and removing jumper on RST pins or by switching power supply off and on. Moreover, memory reset is also part of connection and configuration procedure (see 4.1).

5. TROUBLESHOOTING

Table 6. Troubleshooting			
Issue	Visual indication	Acoustic indication	Solution
No communication with controller	All LED indicators are blinking.	-	1. Check if RACS CLK/DTA bus is properly connected, wires are undamaged and the bus does not exceed 150 m. All devices connected to particular RACS CLK/DTA bus should have common supply minus (GND). 2. Check if the controller is properly configured for communication with the device.
Device configuration error	HOTEL STAFF green LED indicator single blinking every 2 sec.	Short beep every 2 sec.	1. Connect the device to PC with RogerVDM software and configure it again (see 4.1).
Device firmware error	HOTEL STAFF green LED indicator double blinking every 2 sec.	Short double beep every 2 sec.	1. Upload the firmware again (see 4.2)

5. ORDERING INFORMATION

Table 7. Ordering information	
HRT82MF	MIFARE hall card reader, LED indicators and function key, surface wall mounting
HRT82MF-F	MIFARE hall card reader, LED indicators and function key, flush wall mounting
HRT82MF-GP-F	MIFARE hall card reader, flush wall mounting
RUD-1	Communication interface with 12VDC power supply output

6. PRODUCT HISTORY

Table 8. Product history		
Version	Released	Description
HRT82MF v.1.0	07/2014	The first commercial version of the product
HRT82MF v.1.1	03/2015	Modified icon on front panel
HRT82MF v.1.2	10/2018	Removed icons on front panel

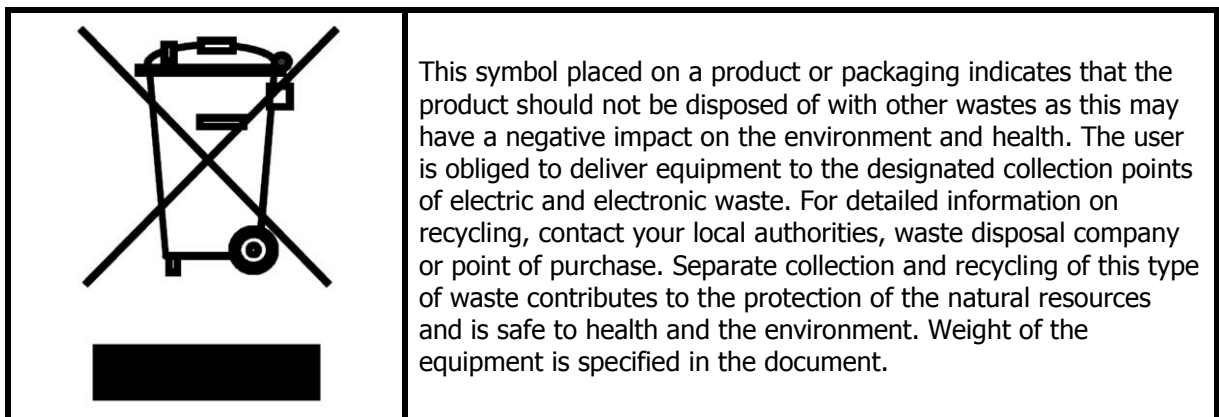

Contact:
Roger sp. z o.o. sp.k.
82-400 Sztum
Gościszewo 59
Tel.: +48 55 272 0132
Fax: +48 55 272 0133
Tech. support: +48 55 267 0126
E-mail: support@roger.pl
Web: www.roger.pl